

MTF

VARIABLE AREA FLOW METER

Operation Manual

MTF- DT- JS- 1022- 2020
/ 01



Preface

Thank you for choosing the products of Dandong TOP Electrical Appliance (Group) Co.

This instruction manual provides you with important information on installation, connection and commissioning as well as for maintenance, troubleshooting and storage. Please read it carefully before installation and commissioning and keep it close to the instrument as an integral part of the product, so that you can refer to it at any time.

You can download this instruction manual by entering the version number at www.ddtop.com.

If the instrument is not operated in accordance with these instructions, the protection provided by the instrument may be impaired.

Trademark, Copyright and Restriction Instructions

Dandong Top Electronics Instrument (Group) Co., Ltd.®, Dandong Top Pump Co., Ltd.®, DDTOP® are registered trademarks of the company.

The performance specifications of this instrument are effective from the date of publication and are subject to change without notice. Dandong Top Electronics Instrument (Group)Co., Ltd. reserves the right to modify the products described in this manual at any time without notice.

Quality Assurance

Dandong Top Electronics Instrument (Group) Co., Ltd. guarantees all LBTC Positive Displacement Rotary Vane Flow Meter to be free from defects in materials and manufacturing processes within one year from the date of delivery.

During the warranty period, Dandong Top Electronics Instrument (Group) Co., Ltd. is responsible for repairing or replacing the equipment free of charge for the buyer (or owner) if the product is returned with quality problems and the claim made is determined to be covered by the warranty after inspection by the manufacturer.

Dandong Top Electronics Instrument (Group) Co. Ltd. shall not be liable for improper use of the equipment, labor claims, direct or subsequent damage, or costs arising from the installation and use of the equipment. Dandong Top Electronics Instrument (Group) Co., Ltd. does not provide any warranty, either express or implied, except for special written warranty certificates for certain products of Dandong Top Electronics Instrument (Group) Co., Ltd.

Quality

Dandong Top Electronics Instrument (Group) Co., Ltd. has passed the ISO9001 quality system certification. The whole production process is carried out in strict accordance with the provisions of the quality system to provide the strongest guarantee for the quality of products and services.

CONTENT

1 Safety Tips.....	5
1.1 An explosion may cause death or serious injury.	5
1.2 Serious injury or death may result from process leakage.....	5
1.3 Failure to comply with safety installation guidelines may result in death or serious injury.5	
2 Product Description	5
2.1 Main product structure - Figure 2-1	5
2.2 Operating Principle Figure 2-2	6
2.3 Packaging.....	6
2.4 Lifting for transport.....	7
2.5 Storage.....	7
3 Technical Characteristics	7
3.1 Main Performance:.....	7
3.2 Main Parameters.....	7
4 Outline drawing for dimensions. Figure 4-1	7
5 Unpacking and Checking	8
5.1 Precautions for unpacking inspection	8
5.2 Check the contents	8
6 Installation	9
6.1 Installation tools.....	9
6.2 Installation technical requirements.....	9
6.3 Installation and Operation Process - Figure 6-1	9
7 Commissioning.....	10
7.1 Electrical wiring	10
7.2 Debugging operation process	11
8 Notes.....	16
9 Failure analysis and troubleshooting	17
10 Disassembly.....	17
10.1 Warnings.....	17
10.2 Waste removal	17
11 Product Certifications.....	18

1 Safety Tips

Unauthorized modification or alteration of the product is expressly forbidden for safety reasons. Repair or replacement is permitted only with parts specified by the manufacturer.

1.1 An explosion may cause death or serious injury.

When installing equipment in explosive atmospheres, always follow applicable local, national, and international standards, codes, and procedures. Ensure that equipment is installed in accordance with intrinsically safe or non-flammable site work procedures.

1.2 Serious injury or death may result from process leakage.

If the process seal is damaged, leakage of media may occur at the connection.

1.3 Failure to comply with safety installation guidelines may result in death or serious injury.

All operations described in these instructions must be performed by trained and qualified or end-user appointed personnel.

2 Product Description

2.1 Main product structure - Figure 2-1

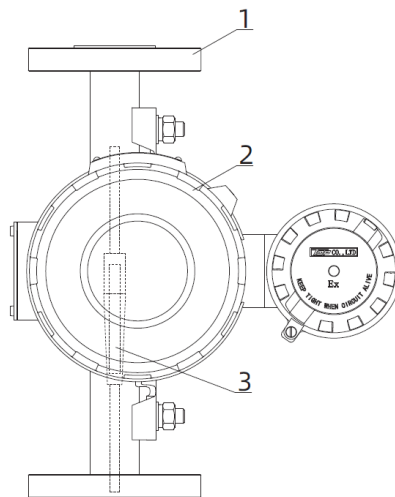

Figure 2-1 Main Product Structure

1. Measuring instrument, including flanges, measuring tubes and float assemblies, and are of the following types.

- Basic: All parts are made of at least 304, suitable for liquid measurements.
- Corrosive: PTFE lined, suitable for measurement of corrosive mediums.
- Jacketed: Suitable for mediums that need to be kept warm or cooled occasions.
- Damping: Suitable for gas and steam measurement.
-

Note: There is no horizontal mounting type for the anti-corrosion or jacketed types.

2. Indicators, dividing into three types:

- Dual Display Type (MTF-A): Both pointer and LCD digital display, with 4 ~ 20mA 2-wire current output and HART protocol communication loaded.
- Digital Display Remote Type (MTF-B): Digital display on LCD screen, with 4 ~ 20mA 2-wire current output and HART protocol communication loaded.
- Local Analog Type (MTF-C): Mechanical pointer indication

3. Float assembly, its specifications is determined according to the range.

2.2 Operating Principle Figure 2-2

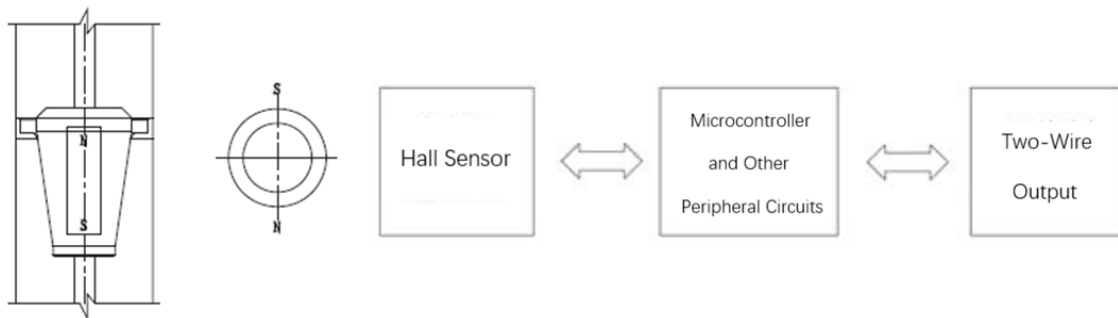

Figure 2-2 Mechanical Transmission, Electrical Schematic

The measured medium flows in from the lower end of the measuring tube, and with the action of the fluid, a differential pressure is generated between the upper and lower ends of the float, and this differential pressure is the lifting force of the float. The float will remain in a certain position when the lifting force applied to the float is balanced with the gravity of the float. The measured flow rate corresponds to the position of the float in the measuring tube, as shown in Figure 1. through the float's built-in magnet coupled with the detection of the magnetic steel on the axis of the indicator, the flow rate is displayed directly on the dial, or through the circuit conversion, the Hall sensor transforms the magnetic signal into electrical signal, and then processed by the controller, the flow rate is displayed on the LCD screen, 4-20mA current signal is output, loading a digital signal compliant with the HART protocol communication.

2.3 Packaging

Please take the packaging waste to a special recycling facility.

2.4 Lifting for transport

Please use qualified lifting equipment and lifting straps, and pay attention to safety.

2.5 Storage

Storage temperature $-20^{\circ}\text{C}\sim 40^{\circ}\text{C}$; storage humidity $\leq 20\%$.

3 Technical Characteristics

3.1 Main Performance:

3.1.1 The MTF Variable Area Flow Meter has passed the national explosion-proof certification, the NEPSI certification

Intrinsically safe Ex ia IIC T4

Explosion-proof Ex d II C T4

3.1.2 Product Performance Standards

JB/T16844 Variable Area Flow Meter;

Q/AMM 014 Variable Area Flow Meter.

3.2 Main Parameters

3.2.1 Power Supply Voltage: 24V DC

3.2.2 Output signal: Two wire, 4 ~ 20mADC , HART protocol communication.

3.2.3 Range ratio: 10:1

4 Outline drawing for dimensions. Figure 4-1

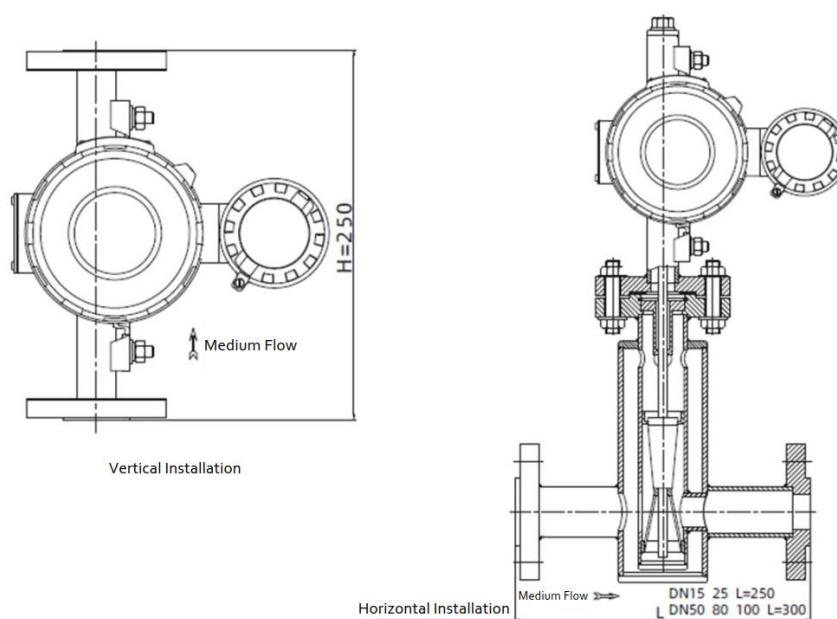

Figure 4-1 Outline drawing for dimensions

The dimensions in the figures are the installation dimensions of standard instruments (when nominal pressure \leq Class600). When the nominal pressure is $>$ Class600, the mounting size of the instrument should be determined according to the specific design.

5 Unpacking and Checking

5.1 Precautions for unpacking inspection

5.1.1 Check whether the Product Name Plate (Figure 5-1) is consistent with the information in the supply list.

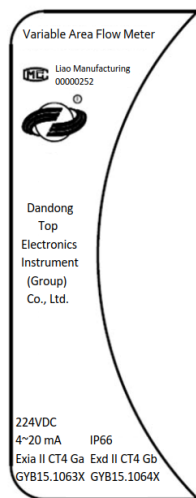

Product Model		Density	
Accuracy			
Range			
Pressure	MPa	Station Number	
Date of Manufacture		Serial Number	

MTF-A Name Plate

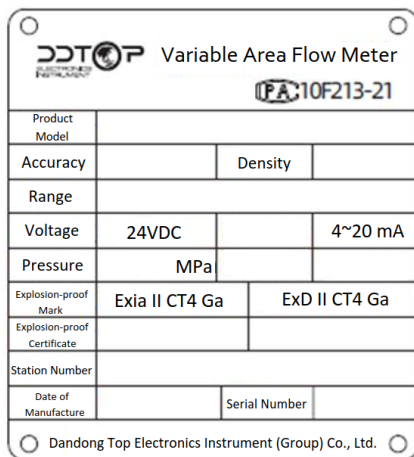

MTF-B Name Plate

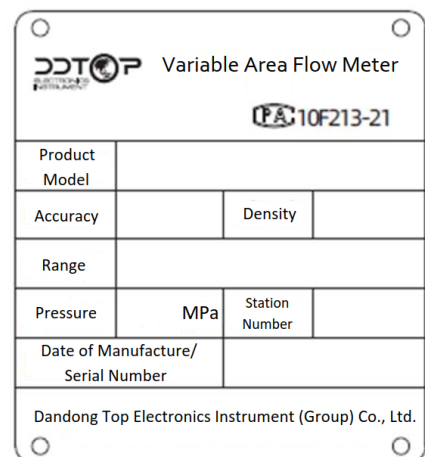

MTF-C Name Plate

Figure 5-1 Product Name Plate

5.1.2 Check whether the quantity and material of each part are correct against the packing list.

5.2 Check the contents

5.2.1 Check the appearance of the meter for defects, damage, etc.

6 Installation

6.1 Installation tools

6.1.1 Wrenches, flange washers and flange bolts for process connections

6.2 Installation technical requirements

6.2.1 When the flowmeter is installed, the pipe fittings connected to the flowmeter should be firmly fixed to avoid the transfer of stress generated by the pipe fittings to the flowmeter's measuring pipe.

6.2.2 According to the needs of inspection, repair, replacement of the flowmeter and cleaning pipeline, bypass pipes should be installed if necessary.

6.2.3 When installing the flowmeter in the new pipeline, the pipeline should be flushed cleanly.

6.2.4 For large size and heavy flow meter, the flow meter should be installed with fixed support when it's necessary, to avoid bending the pipeline.

6.2.5 Valves should be installed upstream of the flowmeter, and the flow control valve is recommended to be installed downstream of the flowmeter at where it's 5~10 times of the nominal diameter.

6.2.6 If the measured liquid contains air bubbles, an air vent should be set upstream of the flowmeter as required.

6.2.7 The flowmeter shall be installed vertically, with the angle between the centerline of the flowmeter and the plumb line not exceeding 5°.

6.2.8 When the flow meter is installed in the pipeline, the minimum division value of the flow meter should be at the bottom.

6.2.9 If there is a backflow in the pipeline, especially due to water hammer, a one-way check valve should be installed after the valve downstream of the flow meter to prevent damage to the flow meter.

6.3 Installation and Operation Process - Figure 6-1

Connect the connecting flange to the field mounting flange, and make sure the flange and gasket contact well.

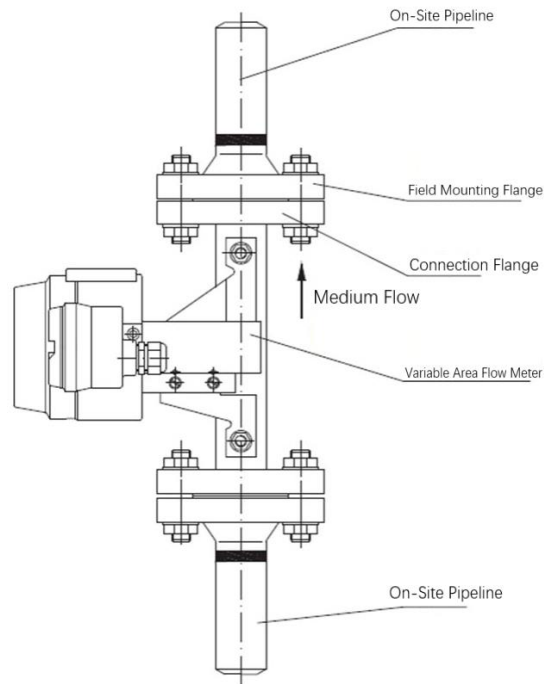
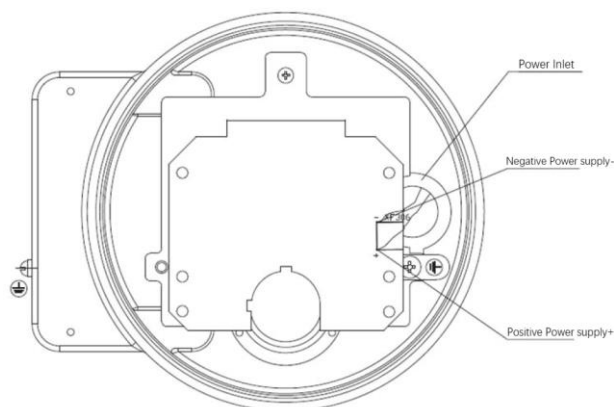

Figure 6-1 Installation Diagram

7 Commissioning

7.1 Electrical wiring

Unscrew the power terminal box cover and introduce the transmission lead into the transmitter meter via the lead-in device (be careful not to break the meter connection when leading). Connect the positive and negative poles of the wires to the corresponding positions (Figure 7-1). After completing the wiring, check that the polarity of the wiring is correct. The meter housing must be well grounded. Then turn on the standard 24VDC power supply.



MTF-A Electrical Wiring Diagram

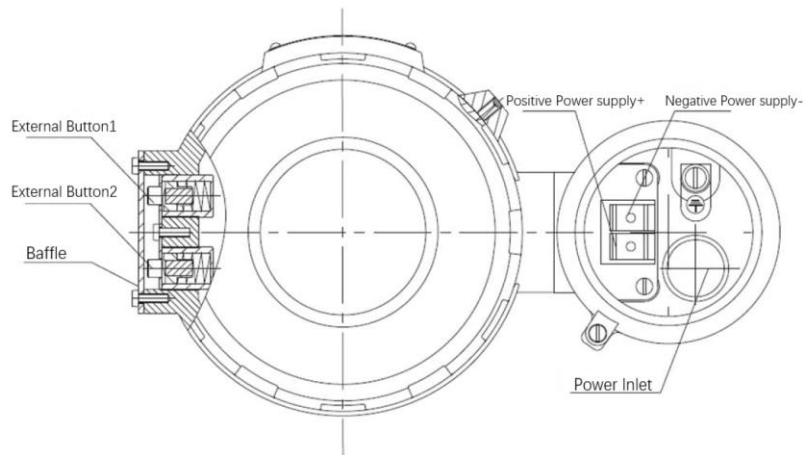

MTF-B Electrical Wiring Diagram
Figure 7-1 Electrical Wiring Diagram

7.2 Debugging operation process

This section describes how to use the 3 local keys (Enter key "←"), (Up key "↑"), (Down key "↓") to configure the parameters in the instrument with the LCD display.

7.2.1 Overview of LCD display functions

Full-screen information is shown in Figure 7-2. variables that the LCD can display include current (Figure 7-3), percentage (Figure 7-4), and main variable (Figure 7-5). The LCD can be set to display a single variable, or it can be set to cycle through the percentage and host variables. The effective bits of the decimal part are settable (0, 1, 2, 3, and 4 decimal places). If percentage and main variable cyclic display are set, the LCD displays both variables alternately in 3-second intervals.

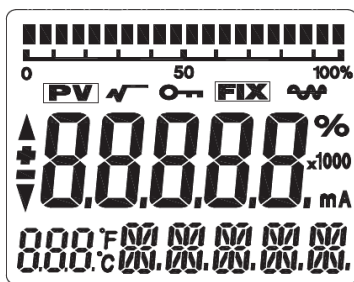

Figure 7-2 LCD Full Screen display

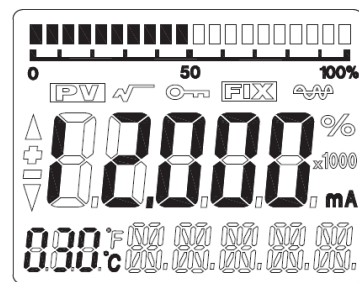

Figure 7-3 Current display

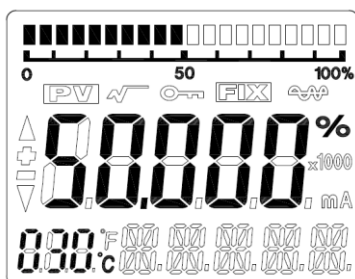

Figure 7-4 Percentage display

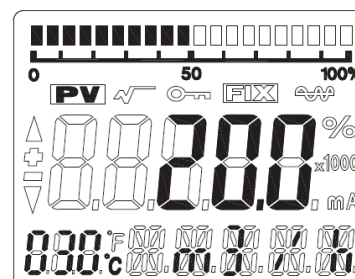

Figure 7-5 Host variable display

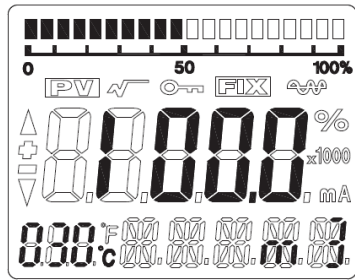





Figure 7-6 Cumulative Display

7.2.2 LCD display symbols description

- ① The symbol  in the right corner of the LCD flashes when HART communication is in progress.
- ② If the output is at the open square, the LCD displays .
- ③ If a fixed output current is set, the LCD displays **FIX**.
- ④ If write protection is enabled, the LCD displays .
- ⑤ The three "888" digits in the lower left corner of the LCD display the temperature of the electronic module and the menu number at the time of configuration.

7.2.3 Key functions description

The LCD panel has a total of three buttons. These three keys are, "←" for the Enter key, "↓" for the Down key, and "↑" for the Up key.

- The "↑" and "↓" keys are used to indicate the increase or decrease of data bits and the shift of the decimal point.
- "←" key is used to access the prompt data setup screen and data saving.

7.2.4 Parameter Configuration Method Description

Press and hold "←", when the "888" character in the lower left corner shows 1~17, the transmitter is in the field configuration mode of the rotating menu. Then you can enter initialization code, modify parameters, calibrate the instrument or migrate by pressing the button.

The data setting process utilizes.

"←" key is used to select the digits and decimal points to be edited and to save.

(Blinking for selected status)

"↑" key is used to make the flashing digits cycle from 0-9 and to move the decimal point to the right.

"↓" key is used to make the flashing digits cycle from 9-0 cycle and to move the decimal point to the left.

The setup process is as follows:

1. Press and hold the "←" key to enter the data configuration interface. The bottom left corner of the screen will show "01" and the data line will show "00005". Press "←" key again, the symbol bit will blink, indicating that the symbol bit can be modified.
2. If you press "↑" or "↓" key, you can change the positive and negative sign of data.
3. Press the "←" key again to complete the selection of symbols. At this time, the first digit starts blinking, indicating that it can be modified. Press the "↑" key or "↓" key for a long time or press the "↑" key or "↓" key several times in a row to set the digit from 0 to 9.
4. Press the "←" key again to finish setting the first digit. The second to fifth digit can be set in the same way as the first digit.
5. After setting the fifth digit, press "←" key to set the decimal point. When the decimal point starts blinking at the same time, the decimal point can be set. Press "↑" key or "↓" key to switch the decimal point position to right or left.
6. When the decimal point is set, press the "←" key. The up and down arrows on the left side are light up, indicating that the setting has been saved.
7. Press the "←" key to set the data again.

7.2.5 Keycode Lookup Table

When the key configuration is used in the field, the "888" bit in the lower left corner of the LCD indicates the current setting menu number, which is the setting function performed by the current key. Its correspondence is"

The "88" display in the lower left corner shows	Set variables
0 or empty	Normal display
1	Formatting
2	Set the unit
3	Set the lower range value
4	Set the upper range value
5	Set the damping time
6	Zeroing out the host variable (zero shift)
7	Zeroing out the accumulated flow rate
8	Current liquid density
10	Small signal excision (percentage)
11	LRV calibration

12	URV calibration
13	Set the measurement medium type (liquid or gas)
14	Current gas density (measured gas)
15	Current gas pressure (measured gas)
16	Current gas temperature (measured gas)
17	View sensor values

7.2.6 Unit Setups

Flow units that can be set are: m³/h, Nm³/h, L/h, kg/h, t/h.

- ① Press and hold down the "←" key to enter configuration mode (No.1 menu will be displayed first, the left up and down arrows are light up).
- ② Press the "↑" key to change the menu to No.2. At the same time, the current unit symbol is displayed in the lower right corner.

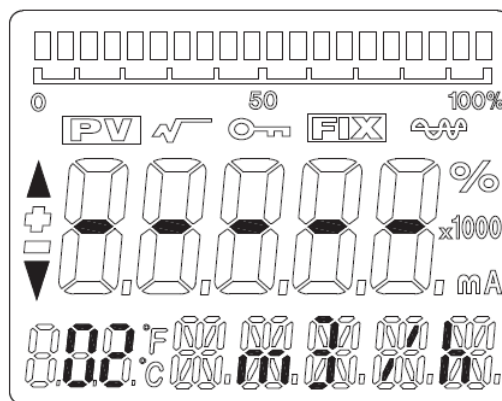

Figure 7-7 Unit Setup

- ③ Press the "←" key again, the unit starts flashing. Press the "↑" key or "↓" key to switch to the unit you want to set.
- ④ Press the "←" key again to finish setting the unit. The up and down arrows on the left side will be light up.

7.2.7 Range Setting

Setting the lower range value LRV

- ① Press and hold the "←" key to enter the configuration mode (No.1 menu will be displayed first, the left up and down arrows will be light up).
- ② Press the "↑" key to change the menu to No.3, and the LCD will show the current LRV value.

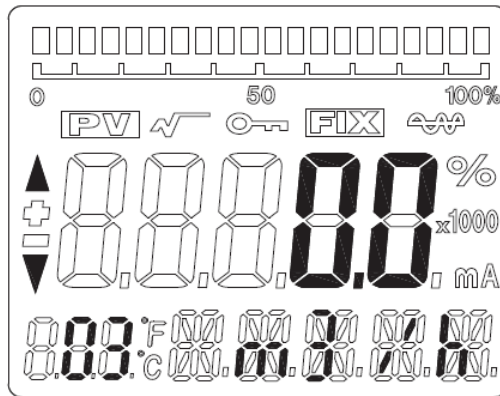

Figure 7-8 LRV Settings

- ③ Press the "←" key again, the symbol starts blinking. Press the "↑" key or "↓" key to switch to the desired plus or minus sign.
- ④ Press the "←" key again to complete the setting. Then, start to set the highest bit of the range. Press the "↑" key or "↓" key to increase or decrease the current flashing digit, and press the "←" key to confirm. Set other digits and decimal points in sequence. When the up and down arrows on the left side are light up, the setting of this menu item is completed.

Setting the upper Range Value URV

Switch the menu to #4 and the LCD displays the current URV value. Repeat the steps ③ and ④ in

7.2.7 for setting again.

7.2.8 Damping setting

Switch the menu to No. 5 and the LCD shows the current damping value. Repeat steps ③ and ④ of 7.2.7 for setting again until complete.

LRV calibration

- ① Adjust the PV value to the zero position (zero flow point).
- ② Switch the menu to No. 11 and the LCD displays the current calibration position value. Repeat the steps ③ and ④ in 7.2.7 again to enter the zero-flow value for zero position calibration.
- ③ Press the "←" key until the up and down arrows on the left side light up to complete the zero position calibration.

URV calibration

- ① Adjust the PV value to the full degree position (full flow position).
- ② Switch the menu to No. 12 and the LCD displays the current calibration position value. Repeat the steps ③ and ④ in 7.2.7 again to enter the full flow value for full degree position calibration.
- ③ Press the "←" key until the up and down arrows on the left side light up to complete the full scale calibration.

Note: Since the MTF is calibrated with 11 points at the factory, it is not recommended to use 2 points in the field.

7.2.10 Zeroing out the host variable (zero shift)

- ① Adjust the PV value to the zero position to be moved to.
- ② Switch the menu to No. 6, and press the "←" key. The "PV0-Y" or "PV0-N" is flashing on the LCD. Press the "↑" or "↓" key to switch to the "PV0-Y" blinking page. Then, press the "←" key, the left arrow will light up. The zero shift is complete.

7.2.11 Zeroing out of accumulations

Switch the menu to No.7, then press the "←" key. The "ACC-Y" or "ACC-N" is flashing on the LCD. Press the "↑" or "↓" key to switch to the "ACC-Y" blinking page. Then press "←" key, the left arrow lights up and the accumulator is cleared.

7.2.12 This product has two external keys, which can be operated by opening the bezel.

External key 1 has the same function as the "←" key.

External key 2 has the same function as the "↑" key.

Note: The key configuration process will not exit automatically, you need to exit the key configuration manually. The method is to press "↑" key or "↓" key successively in the switch menu state, the menu will be increasing or decreasing. When the menu is greater than 17 or less than 1, it will exit the key configuration state, and enter the normal output mode.

8 Notes

8.1 Do not open the display case during normal use.

8.2 The actual operating conditions shall be the same as the design conditions. Any changes will require the instrument to be returned to the factory for recalibration.

8.3 During disassembly, the instrument shall be protected from force damage as far as possible, and care shall be taken to avoid damage to the threaded surface of the explosion-proof product.

8.4 Ensure that the power supply is safe and reliable, and that it is connected in accordance with the correct positive and negative polarity.

8.5 The use of rotameter is not suitable for applications with high shock and vibration.

8.6 The operating temperature range of the electronic components is $-40^{\circ}\text{C} \sim +70^{\circ}\text{C}$; the temperature range of the LCD screen is $-20^{\circ}\text{C} \sim +70^{\circ}\text{C}$ (out of the range, no display of the LCD, telecommunication is normal).

8.7 The power supply should be cut off before repairing the instrument.

8.8 Tighten the housing cover after commissioning to prevent water and moisture from entering the instrument.

9 Failure analysis and troubleshooting

Failure Description	Causes	Troubleshooting Method
Display stops sometimes.	There's debris on the float.	Install magnetic filters upstream
The needle of the indicator is jittering, and indication is not correct.	Unstable medium working pressure.	Install damping device.
There is flow in the field, but no change in the meter.	The medium may have solidified due to low temperature, resulting in no change in flow or a stuck float.	Add heat to important parts of the instrument to reduce medium solidification. If the instrument still does not work properly, then check the float measuring tube.
Less than 20% of instructions.	Damping ring has impurities or float guide rod is not straight	Re-grind the damping ring with sandpaper and straighten the guide bar.
Pointer does not change at maximum, but changes after vibration.	There might be impurities on the float damper.	Clean impurities from the measuring section of the instrument and re-install it
Instructions are inaccurate.	Damping ring is not flexible or stuck by impurities.	Clean the measuring tube or add filters.
Show CURFL	Loop Current Fault.	1. Check whether the grounding is reliable. 2. Recalibration. 3. Instrument circuit function damage.
Display CCSFL	Sensor excitation failure	Open sensor or faulty circuit board

10 Disassembly

10.1 Warnings

Before disassembly, attention should be paid to hazardous process conditions, e.g., pressure in the vessel, hot, corrosive, or toxic media, etc.

10.2 Waste removal

Please follow the existing guidelines for waste disposal in your region.

11 Product Certifications

Product Certification		
Type of Certification	Certificate Number	Scope/Description of Certification
ATEX	 Sira 19ATEX1143X	II 1G Ex db IIC T* Gb Ta=-40°C to 60°C/70°C/80°C II 2G Ex ia IIC T* Gb Ta=-40°C to 70°C
IECEX	 IECEX SIR 19.0046X	Ex db IIC T* Gb Ta=-40°C to 60°C/70°C/80°C Ex ia IIC T* Gb Ta=-40°C to 70°C
EMC	 AE 50467900001	
Explosion Proof Certificate	 Intrinsically safe/Isolated CE20.5173X	Ex b IIC T6/T5/T4/T3 Ex ia IIC T5/T4 Ga
Pattern Approval of Measuring Instrument	 10F213-21	